

Dimensions & Specifications

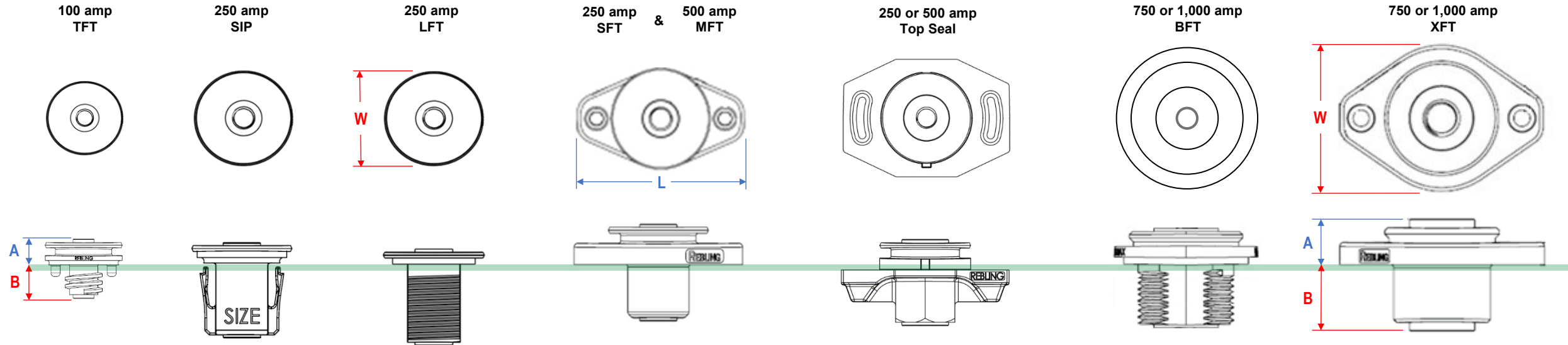

Parameter	TFT	SIP	LFT	SFT & MFT	Top Seal	BFT	XFT
Rated Current (amps)	100	250	250	250 or 500	250 or 500	750 or 1,000	750 or 1,000
Peak Current (amps)	600	1,500	1,500	1,500 or 3,000	1,500 or 3,000	4,000 or 5,000	4,000 or 5,000
Electrical Connection Bolt Size	M5	M8	M8	M8	M8	5/16	M10
Cross Sectional Area of Conductor	40 mm ²	130 mm ²	130 mm ²	130 mm ² or 240 mm ²	130 mm ² or 240 mm ²	390 mm ²	390 mm ²
"W" Dimension	1.03" (26.2mm)	1.34" (34.0mm)	1.34" (34.0mm)	1.34" (34.0mm)	1.74" (44.2mm)	1.96" (49.8mm)	1.95" (49.5mm)
"L" Dimension	1.03" (26.2mm)	1.34" (34.0mm)	1.34" (34.0mm)	2.25" (57.2mm)	2.47" (62.7mm)	1.96" (49.8mm)	2.75" (69.9mm)
"A" Dimension w No gasket	0.35" (8.9mm)	0.28" (7.1mm)	0.20" (5.1mm)	0.53" (13.5mm)	0.45" (11.4mm) – Panel Thickness	0.49" (12.5mm)	0.54" (13.7mm)
"B" Dimension w No gasket	0.46" (11.7mm)	0.99" (25.1mm)	1.07" (27.2mm)	0.74" (18.8mm)	0.82" (20.8mm) + Panel Thickness	0.86" (21.8mm)	0.95" (24.1mm)
"A" Dimension with gasket	0.35" (8.9mm)	0.28" (7.1mm)	0.28" (7.1mm)	0.61" (15.5mm)	0.45" (11.4mm) – Panel – Gasket(s)	0.57" (14.5mm)	0.62" (15.7mm)
"B" Dimension with gasket	0.46" (11.7mm)	0.99" (25.1mm)	0.99" (25.1mm)	0.66" (16.8mm)	0.82" (20.8mm) + Panel + Gasket(s)	0.78" (19.8mm)	0.87" (22.1mm)
IP Rating w Gasket or O-ring	IP68-watertight	IP68-watertight	IP68-watertight	IP68-watertight	IP68-watertight	IP68-watertight	IP68-watertight
Recommended Panel Material	Metal or Plastic	Metal	Metal	Metal or Plastic	Metal or Plastic	Metal	Metal or Plastic
Min Panel Thickness	0.025" (0.6mm)	0.057" (1.4 mm)	0.11" (2.8mm)	0.025" (0.6mm)	0.040" (1.0mm)	0.080" (2.1mm)	0.025" (0.6mm)
Max Panel Thickness	0.157" (4.0mm)	0.255	0.70" (17.8mm)	0.55" (14.0mm)	0.185" (4.7mm)	0.50" (12.7mm)	0.70" (17.8mm)
Panel Mounting Method	Panel Nut	Snap In - No Hardware	Panel Nut	Panel Screws	Flat Head Sheet Metal Screws	Panel Nut	Panel Screws
UL94 Flammability	V-0	V-0	5VA	V-0	V-0	5VA	V-0

Cable and Terminal Selection Guidelines (Temperature Rise vs Current)

courtesy of Rebling.com

September 9, 2025

Product Category	Industry Standard or Test Results	Product		Tool Required for Mating & Un-mating	Cross Sectional Area of Conductor mm ²	# amps for 30° C Rise 55° total	Temperature for Human Contact with Metal			Temperature for Human Contact with Plastic		
							# amps for 45° C Rise 70° total	# amps for 60° C Rise 85° total	# amps for 90° C Rise 115° total	# amps for 45° C Rise 70° total	# amps for 60° C Rise 85° total	# amps for 90° C Rise 115° total
Connector	Test Results	Rebling BFT or XFT	1,000 amp rating with one 380 mm ² cable per terminal	Wrench	390	1,010	1,250	1,430	1,690			
Connector	Test Results	Rebling BFT or XFT	750 amp rating with one 380 mm ² cable per terminal	Wrench	390	900	1,100	1,250	1,440			
Connector	Test Results	Rebling MFT or Top Seal	500 amp rating with one 230 mm ² cable per terminal	Wrench	240	520	630	730	840			
Connector	Test Results	Rebling LFT, SIP, SFT, Top Seal	250 amp rating with one 105 mm ² cable per terminal	Wrench	130	280	340	390	450			
Connector	Test Results	Anderson SB350	with one 105 mm ² cable per terminal	None	130	280	340	390	450			
Connector	Test Results	Rebling 7010+7020	with one 105 mm ² cable per terminal	None	75	270	330	380	430			
Connector	Test Results	Rebling TFT	100 amp rating with one 32 mm ² cable per terminal	Wrench	40	115	150	170	190			
Cable	Test Results	750 MCM Cable	7,600 strands of 30 gauge wire		380	1,020	1,270	1,470				
Cable	Test Results	450 MCM Cable	4,500 strands of 30 gauge wire		230	550	660	770				
Cable	Test Results	250 MCM Cable	2,500 strands of 30 gauge wire		130	360	450	520				
Cable	Test Results	4/0 Cable	2,060 strands of 30 gauge wire		105	290	350	400				
Cable	Test Results	3/0 Cable	1,590 strands of 30 gauge wire		80	260	310	350				
Cable	Test Results	2/0 Cable	1,280 strands of 30 gauge wire		65	240	290	335				
Cable	Test Results	1/0 Cable	1,000 strands of 30 gauge wire		50	230	270	315				
Cable	Test Results	2 AWG Cable	625 strands of 30 gauge wire		32	120	160	180				
Cable	Test Results	4 AWG Cable	375 strands of 30 gauge wire		19	90	105	120				
Cable	Test Results	6 AWG Cable	260 strands of 30 gauge wire		13	80	100	110				
Cable	Test Results	8 AWG Cable	160 strands of 30 gauge wire		8.1	75	90	105				
Cable	Test Results	10 AWG Cable	105 strands of 30 gauge wire		5.3	50	60	70				
Cable	Test Results	12 AWG Cable	65 strands of 30 gauge wire		3.3	35	40	50				
Cable	Test Results	14 AWG Cable	40 strands of 30 gauge wire		2.0	20	25	30				
Cable	NEC/UL Std	4/0 Cable	2,060 strands of 30 gauge wire		105	195	230	260				
Cable	NEC/UL Std	2/0 Cable	1,280 strands of 30 gauge wire		65	145	175	195				
Cable	NEC/UL Std	1/0 Cable	1,000 strands of 30 gauge wire		50	125	150	170				
Cable	NEC/UL Std	2 AWG Cable	625 strands of 30 gauge wire		32	95	115	130				
Cable	NEC/UL Std	6 AWG Cable	260 strands of 30 gauge wire		13	55	65	75				

Cable and Connector Selection Guidelines: The cross sectional areas of the terminal and the cable attached to the terminal should be the same. Attaching a small cable to a large terminal is like attaching a 1 inch pipe to a 4 inch fitting, the size of the cable will limit the system's electrical and thermal performance, not the terminal. To select the optimal connector, follow the steps below:

Step 1: determine the temperature rise your equipment design can tolerate. The higher the temperature rise your equipment can tolerate, the lower the cost of cable and connectors.

Step 2: determine if your equipment needs to comply with UL, NEC, IEC or other standards

Step 3: determine the steady state current which your equipment must handle. If there are frequent or extended peaks of higher currents, use these peaks to estimate an average steady state current.

Step 4: select the smallest cable which can carry your steady state current which does not exceed the temperature rise you can tolerate and which conforms to the standard with which you wish to comply.

Step 5: determine if your equipment needs a separable electrical connection. Separable connections are more expensive and less reliable than permanent (soldered or welded) connections.

Step 6: determine if it is acceptable to use a tool to un-mate your electrical connection. Tool-less connectors are more expensive and less reliable than connectors which require tools but might be justifiable if: frequent un-matings occur, the installer is unskilled, a 20 second reduction in maintenance time is critical or lowered assembly labor costs offset the increased cost of the tool-less connector.

Step 7: select the lowest cost connector which: does not exceed the temperature rise your equipment can tolerate at your steady state current and meets your un-mating tool requirements.

Temperature Rise Values: the NEC (National Electrical Code) values are NEC's recommendations for typical thermoplastic insulated cables enclosed in a conduit which are close to other cables. UL has adopted NEC's 45° C rise values as their recommendations for current levels per cable size in UL 98. The values labeled "Test Results" were obtained from current vs temperature rise testing of individual cables and connectors suspended in air inside an 18" x 18" x 18" test chamber. Lithium battery system designers usually select components which keep the temperature rise to a maximum of 30° C due the sensitivity of lithium cells. It is wise to compare connectors based upon temperature rise test results since the rated currents and total allowable temperatures defined by standards like UL1977 and IEC 61984 can vary by a factor of 2.5. The current vs temperature rise characteristics of your application may be significantly different than the assumptions used in NEC, UL or IEC standards.

Touch Safe Temperatures: IEC/UL 60950-1 defines the maximum allowable temperature for 3 seconds of contact between a metal component and the human body as 60° C; for plastic it's 85° C.

Cross Sectional Area of Conductor: the cross sectional areas of the stranded cables shown above were calculated using the diameter of one 30 gauge wire = 0.01000 inches